

AMBIR®

LP230-NE

Thermal Wristband & Label Printer

USER GUIDE

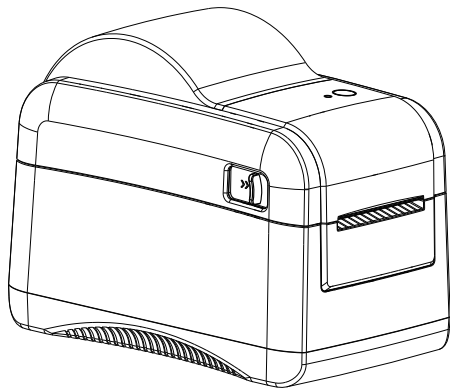

Thank you for your purchase of the LP230-NE
Go to www.ambir.com/LP230-Setup
For detailed installation instructions.

www.ambir.com

Product View

Paper Feed Button
LED Indicator Light



Side View

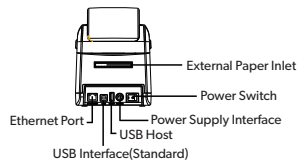

Rear View

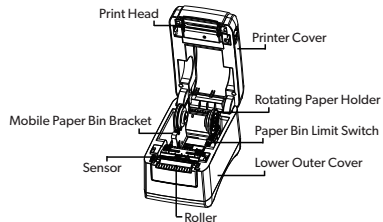

Internal Diagram

1

What's In The Box



1 - Printer
1 - AC Adapter
1 - Power Cord

1 - USB Cable
1 - User Manual

Printer Installation Instructions

Step 1. Place the printer on a flat surface and make sure the power switch is turned off.

Step 2. Plug in the USB Cable/Ethernet Cable and Power Cable to the ports on the back of the printer plug the other end into the computer host/network and power source. Switch on the printer power.

Step 3. Download and install the printer driver from www.ambir.com/LP230-Setup/ Detailed instructions will be on this webpage.

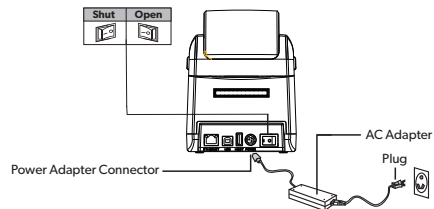

2

Installing Media

- 1) Using both hands push down on the cover opening switch on both sides of the printer and pull up.
- 2) Move the rotating paper older to the left. Make sure the unlock switch is in the unlock position.
- 3) Place the media roll between the holder and let go. The holder will clamp the media roll in place.
- 4) Pull the media out from the roll and over the paper sensor and roller.
- 5) Adjust the media guide to line up with the media.
- 6) Press down on the printer cover firmly with both hands to close the cover. The media is now installed.



1

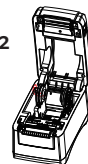

2

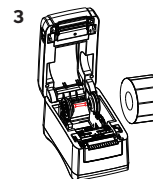

3

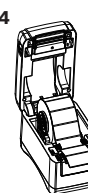

4

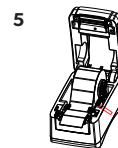

5

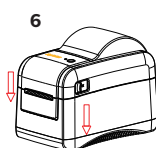

6

3

General Key Function

- 1) Paper Feed: When not printing pressing the paper feed button will feed 1 label.
- 2) Pause: When printing pressing the paper feed button will pause the print job.
- 3) Self Inspection: To get printer information from the device turn off the printer and hold down the paper feed button. Power on the printer and wait until the purple light flashes 3-5 times and release the paper feed button.
- 4) Calibrating Paper Sensor: To calibrate the paper sensor turn off the printer and hold down the paper feed button. Power on the printer and wait until the red light flashes 3-5 times and release the paper feed button.
- 5) Resting Printer Defaults: To reset the printer defaults turn off the printer and hold down the paper feed button. Power on the printer and wait until the blue light flashes 3-5 times and release the paper feed button.

LED Notification Description

LED Indicator Status	Description
Red Light Flashing	Printer error or out of paper
Red Light Always On	Cover Open or Printer Overheating
Blue Light Flashing	Printing Paused
Blue Light Always On	The printer is powered on and in a normal printing state

Troubleshooting

The following list are some common issues that may arise while using the printer and how to solve them. If you have a issue with the printer and following the troubleshooting steps and the printer still does not function properly, please go to www.ambir.com/support for more support.

Problem	Possible Reason	Solution
Indicator Light Not On	Printer is not receiving power.	Check power cable connections and ensure the power switch.
Indicator Light Blinking Red	Paper jam, low media, or printer cover not properly closed.	Open the printer, clear any jams, reload media, and securely close the cover.
Media is Folding	Incorrect media loading or excessive tension.	Reload the media ensuring it is in the paper feeder properly. Adjust media guides to make sure they are not too tight.

Maintenance

To maintain optimal performance of the printer it is recommended to clean the printer regularly. The interval depends on usage. If you notice issues with print quality please follow the instructions to clean the printer.

Note: Please wait 3 to 5 minutes after printing has been completed to clean the printer. Do not touch the print head with your hands as oils can impact printing.

Cleaning Steps:

- 1) Turn off the printer and open the printer cover.
- 2) Wipe down the print head, paper sensor and roller using a lint free cloth or cotton swab with isopropanol alcohol. Try to get any debris off the print head and roller.
- 3) Wait 5 to 10 minutes after cleaning for the alcohol to dry and try printing again.

Problem	Possible Reason	Solution
Printing Quality Issues	Dirty printhead, incorrect media, or low print density settings.	Clean the printhead with a lint-free cloth and isopropyl alcohol, use compatible media, and adjust print density in settings.
Label Not Printing	Printer is paused, incorrect label size, or sensor issue.	Resume printing, check label settings in the printer driver, and ensure the label sensor is clean and correctly positioned.
Left or Right Label Content is Missing	Misaligned media or incorrect print width settings.	Re-align the media and adjust the print width settings in the printer driver or software.
White or Black Lines on Labels	Dirty or damaged printhead.	Clean the printhead and roller. Follow cleaning instructions.